

GSS16

GSS10

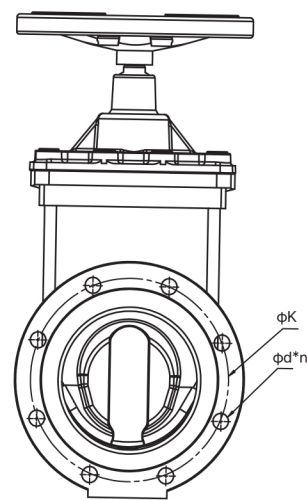
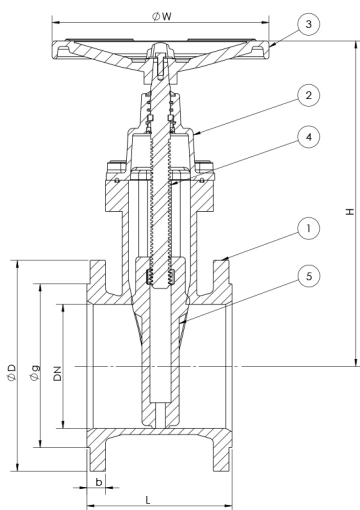

General Specification

Maximum Working Temperature 110 °C
PN 10 / 16 bar

Standards

Design : EN1171
Face To Face Dimensions : EN558 (F4,F5)
Machining And Drilling Of Flanges : EN1092-2
Test And Inspection : EN12266-1

Applications

Water, Waste Water And HVAC

ویژگی های محصول

ماکزیمم دمای کاری 110 درجه سلسیوس
فشار کاری 10 / 16 بار

استاندارد

طراحی: EN 1171
وجه تا وجه: EN558 (F5 , F4)
ماشین کاری و سوراخ کاری فلنج ها: EN1092-2
تست و بازرسی: EN12266-1

کاربرد

صنایع آب و فاضلاب، تاسیسات حرارتی-برودتی و تبویه مطبوع

DN (mm)	L		H	W	Weight (kg)		PN10					PN16				
							D	K	g	b	d*n	D	K	g	b	d*n
	14	15			14	15										
50	150	250	237.5	140	14	15	165	125	99	20	19*4	165	125	99	19	19*4
65	170	270	282.5	160	15	16	185	145	118	20	19*4	185	145	118	19	19*4
80	180	280	315	200	19	20	200	160	132	22	19*8	200	160	132	19	19*8
100	190	300	355	200	24	25.5	220	180	156	24	19*8	220	180	156	19	19*8
125	200	325	420	250	32	36.5	250	210	184	26	19*8	250	210	184	19	19*8
150	210	350	467.5	250	42	49	285	240	211	26	23*8	285	240	211	19	23*8
200	230	400	560	315	60	69.5	340	295	266	26	23*8	340	295	266	20	23*12
250	250	450	653	400	86	100	400	350	319	28	23*12	400	355	319	22	28*12
300	270	500	728	500	122	141	455	400	370	28	23*12	455	410	370	24.5	28*12

NO	Part Name	Material
1	Body	GG25 / GGG40
2	Bonnet	GG25 / GGG40
3	Handwheel	Stamped Steel / GGG40
4	Stem	AISI 420
5	Wedge	GGG40 Coated with EPDM / NBR